



CUMIN - DILAN

HIL testing with the Nissan LEAF electric drive



Marco DUQUESNE
Walter LHOMME

Master 2 VIE & L2EP



Outline



Context



HIL testing



Simulation results



Conclusion



<https://cumin.univ-lille.fr/>

Context

Project positioning

SARA

Driver survey using the Nissan LEAF car



Measuring data

Real energy consumption from car

DILAN

Driving simulator

Nissan LEAF electric drive testbench



Measuring data

Real car energy consumption from testbench at the lab.

Comparison

Objective

Development of the HIL testing of the Nissan LEAF

HIL = Hardware In the Loop

Emulation of the load at the laboratory

Structural scheme of the Nissan LEAF

Vehicle and environment

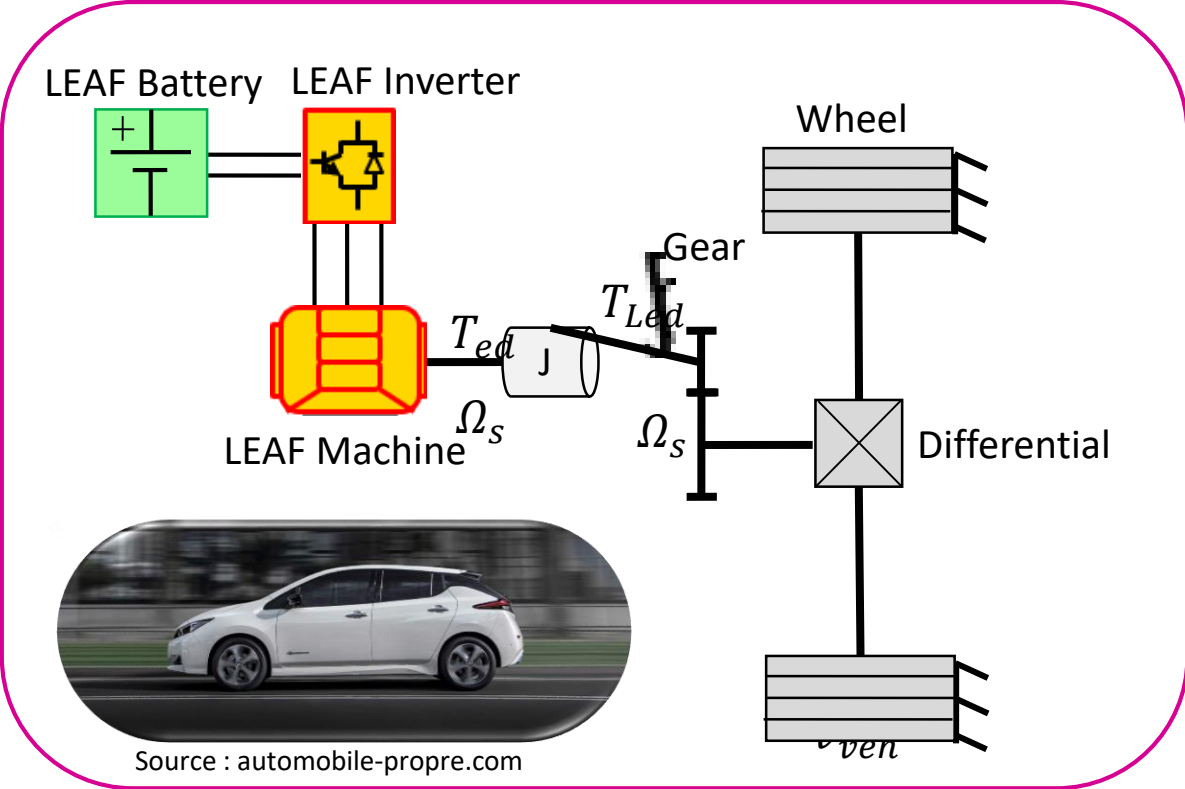

Structural scheme of the test bench

Laboratory

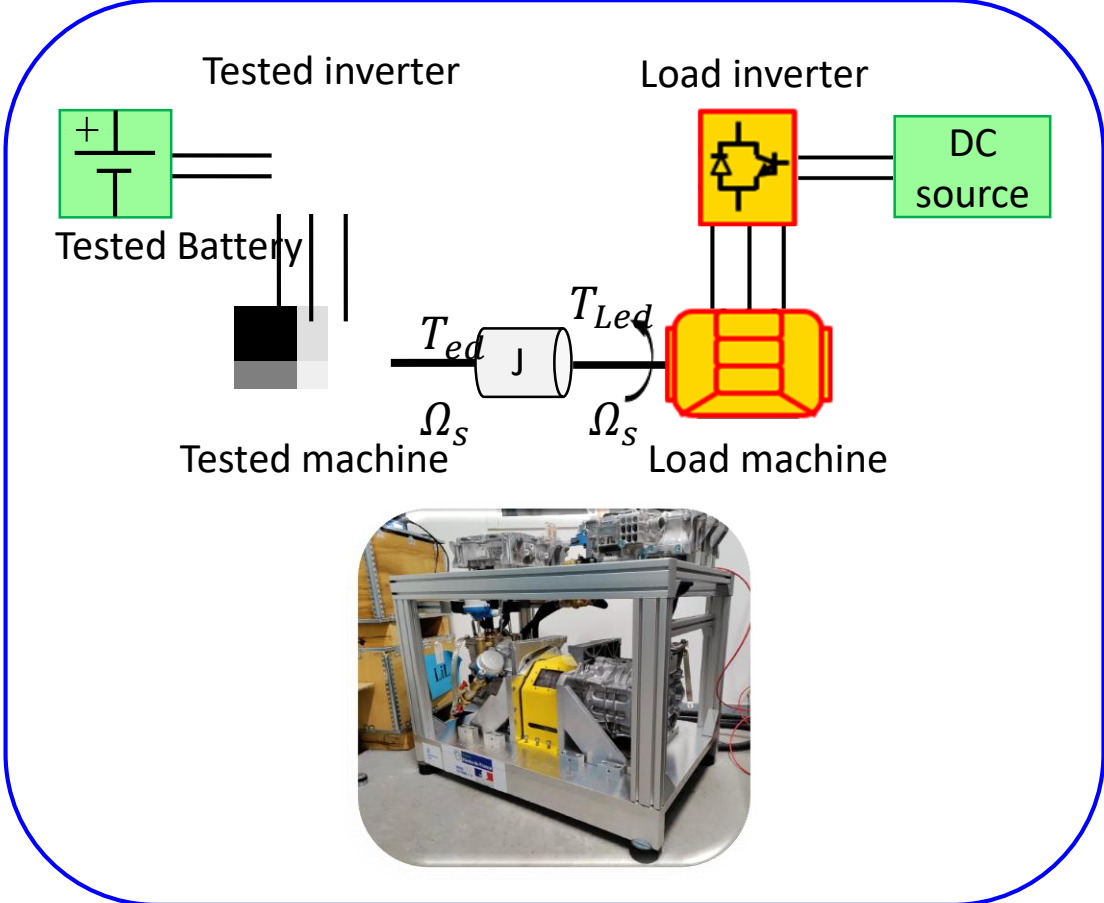

HIL principle apply to the bench

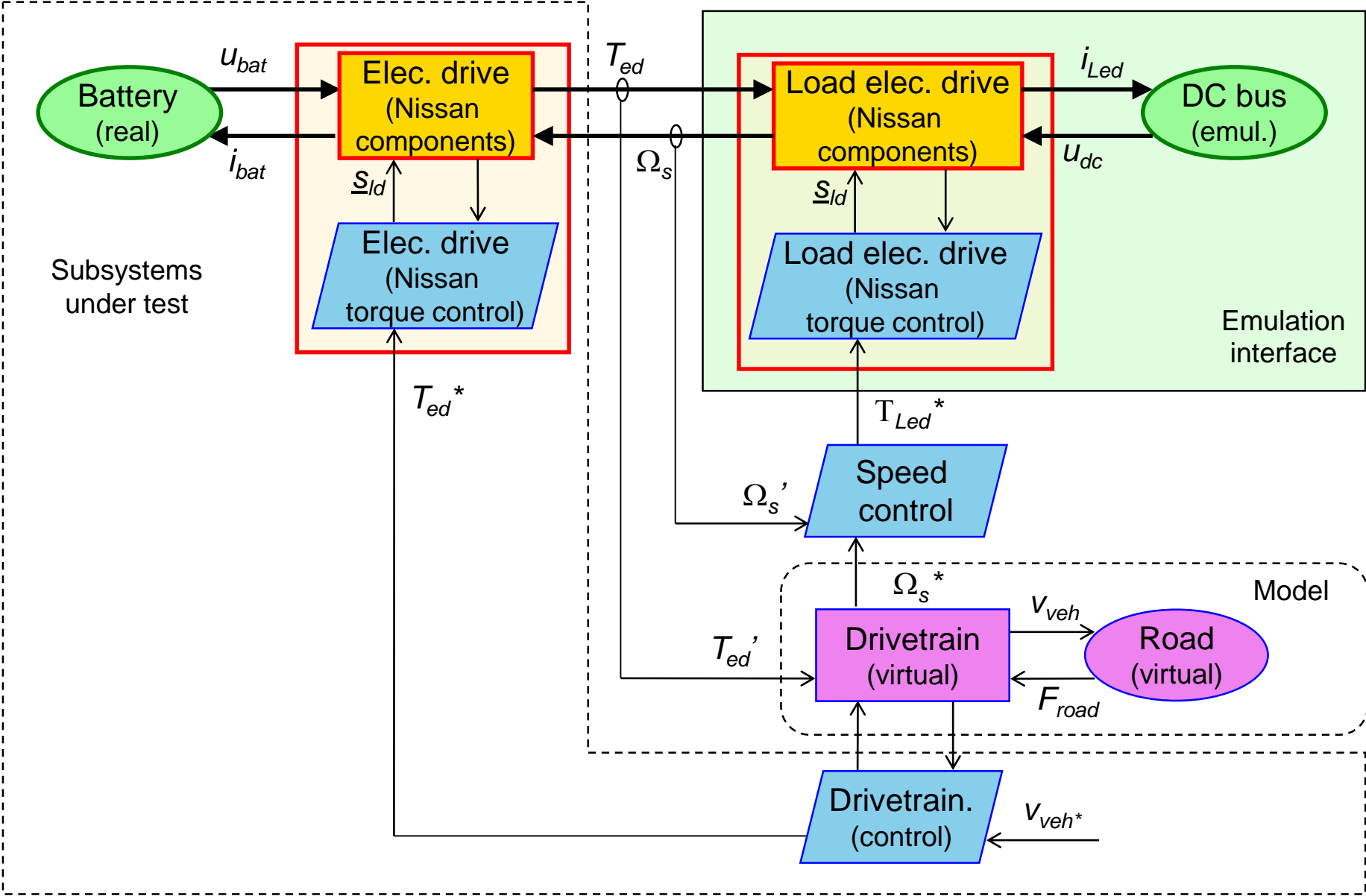



<https://cumin.univ-lille.fr/>

HIL testing



EMR of the Nissan LEAF

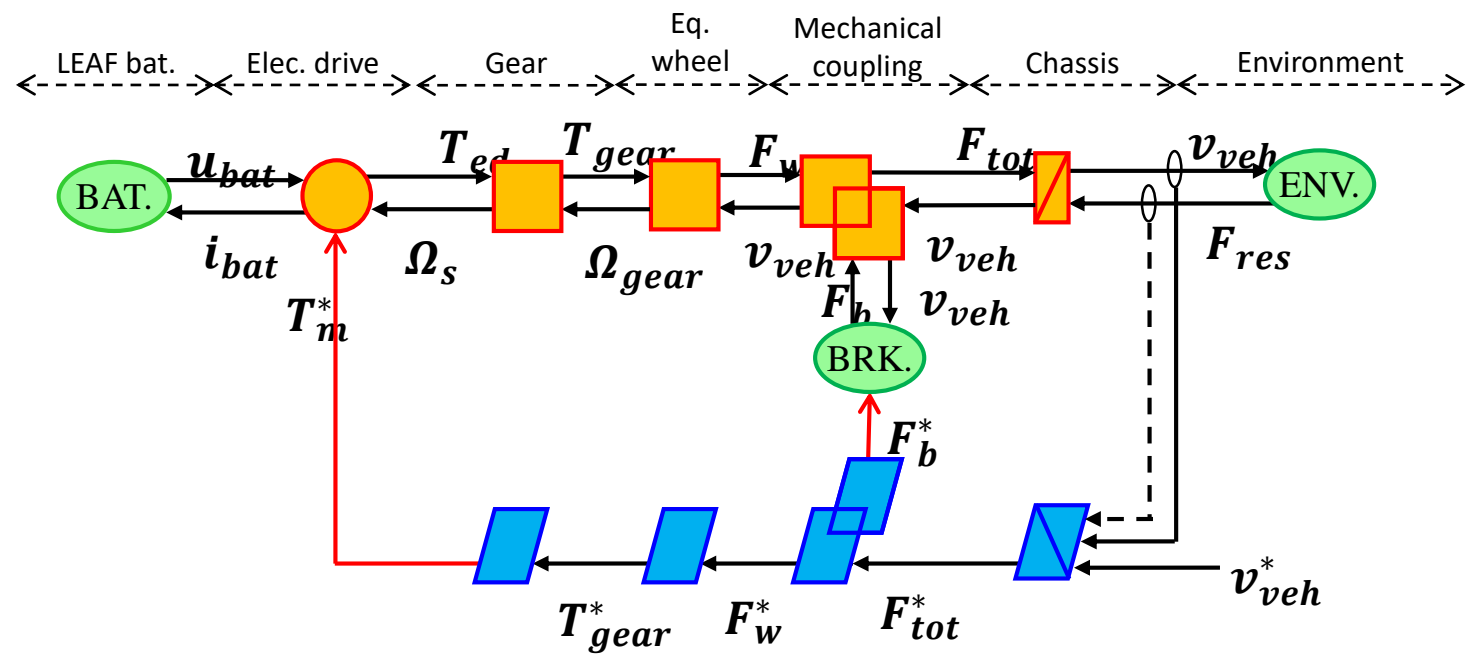

Structural scheme of the Nissan LEAF

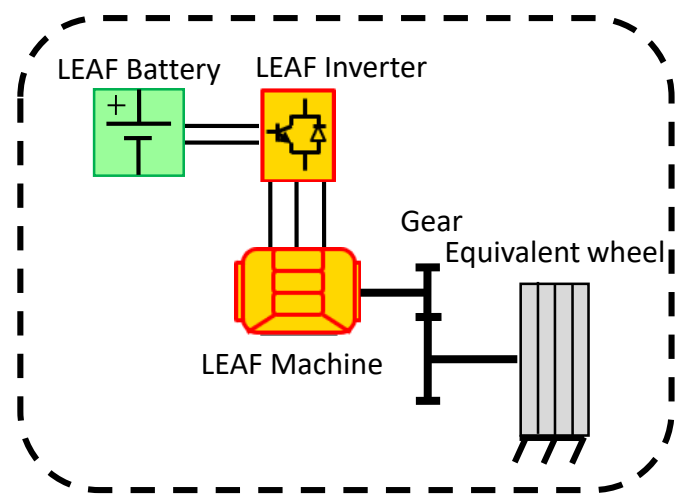

HIL testing using EMR

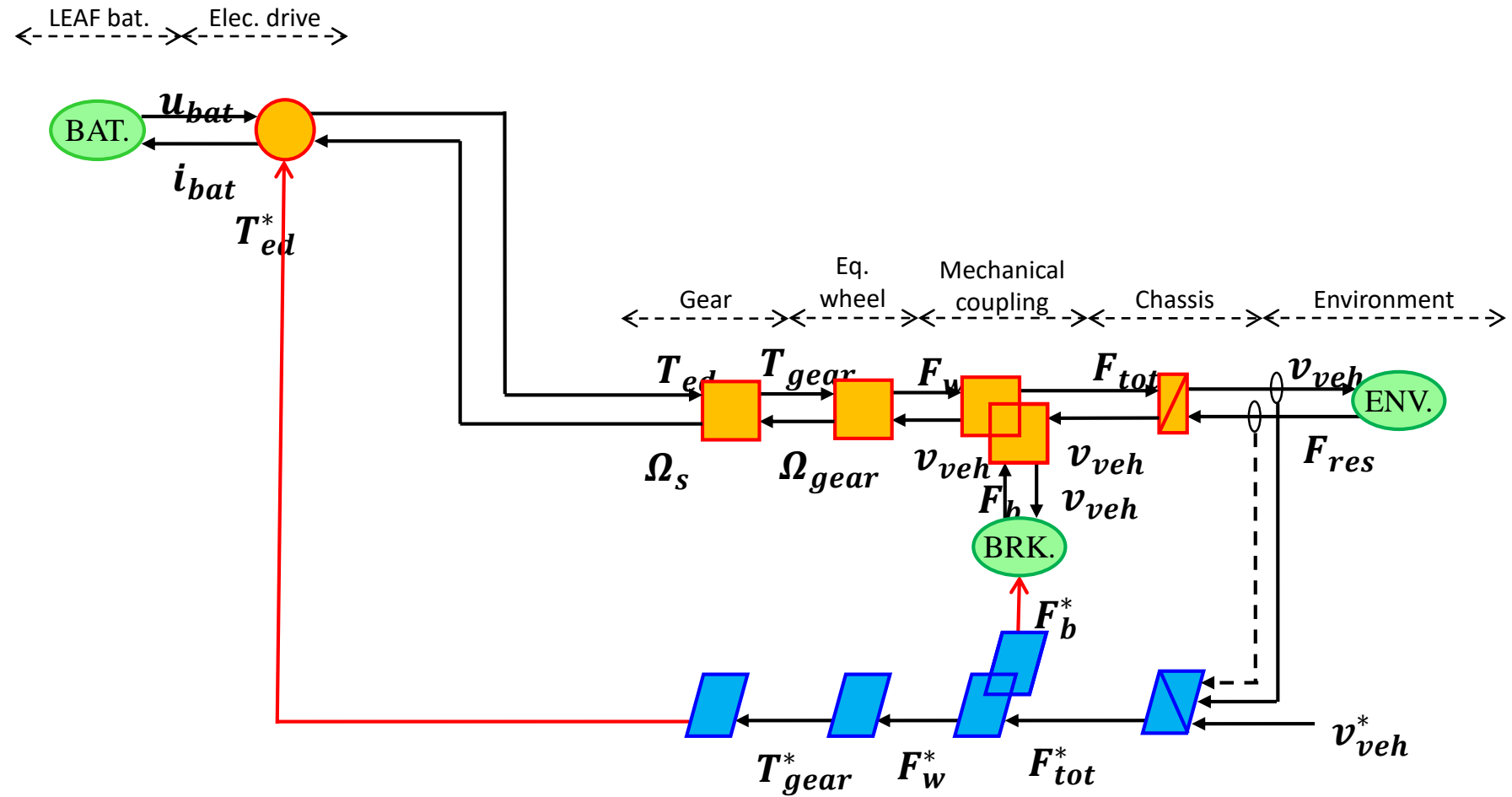

HIL testing using EMR

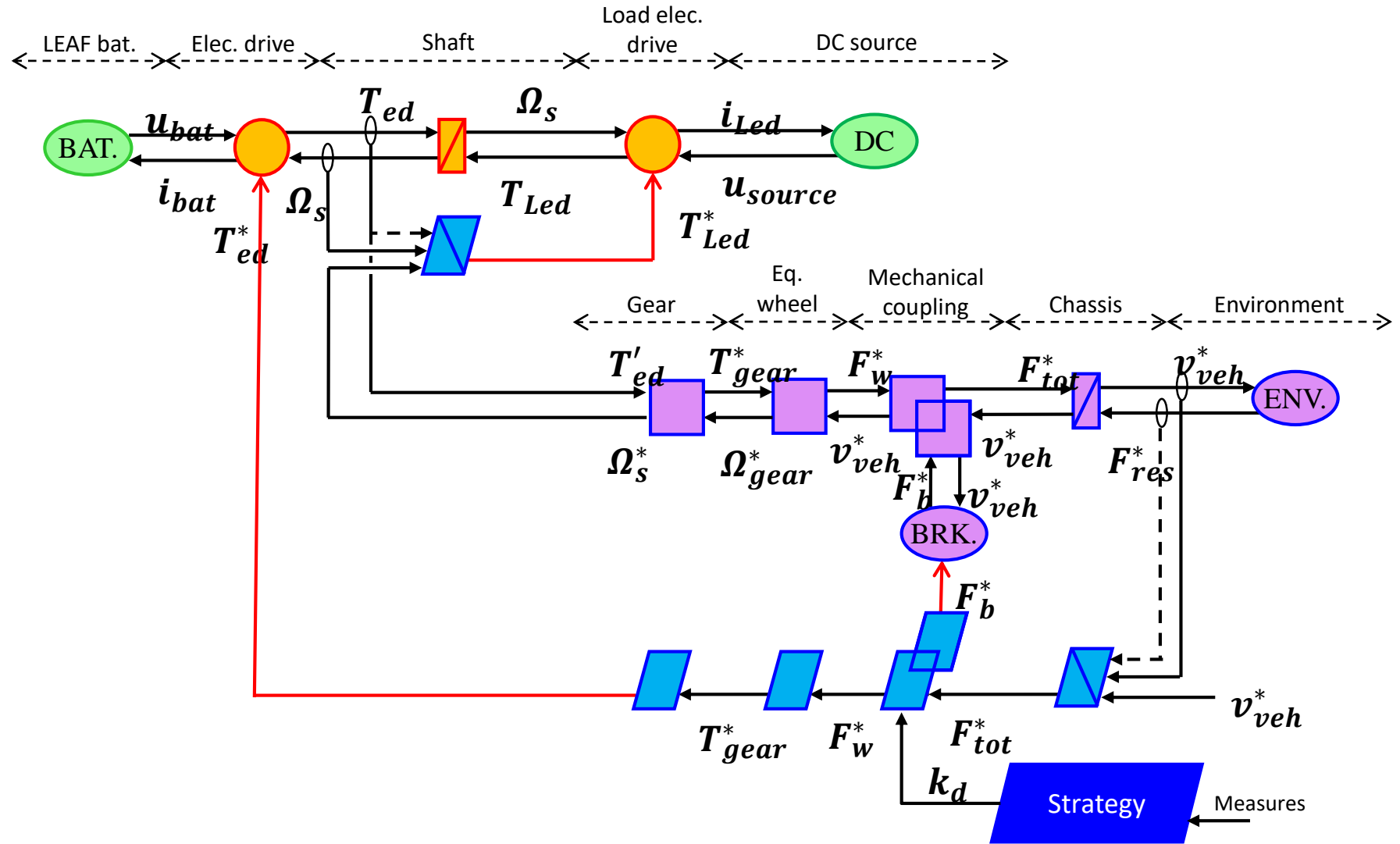

HIL testing with real driving cycle

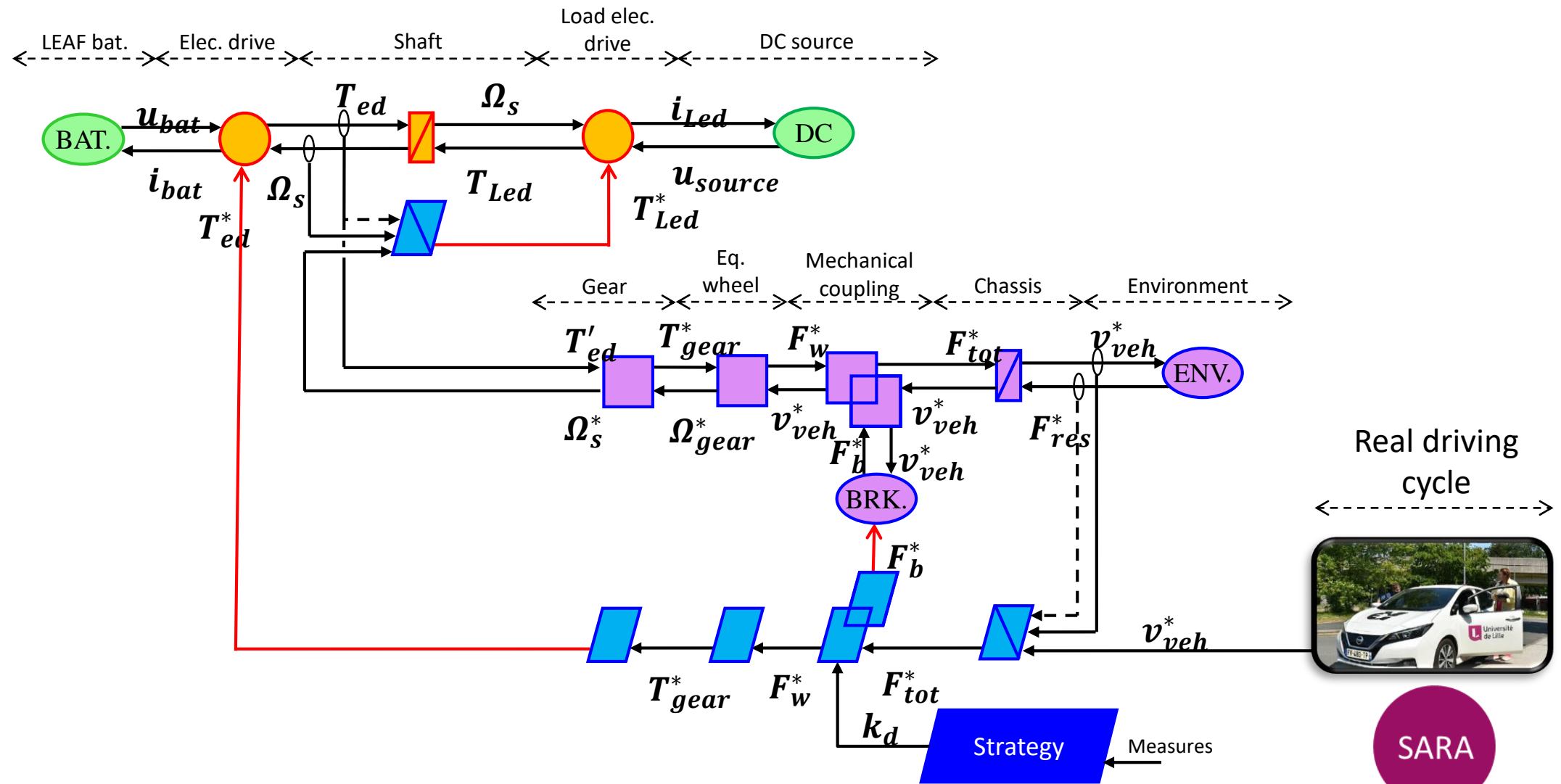

HIL testing piloted by driving simulator

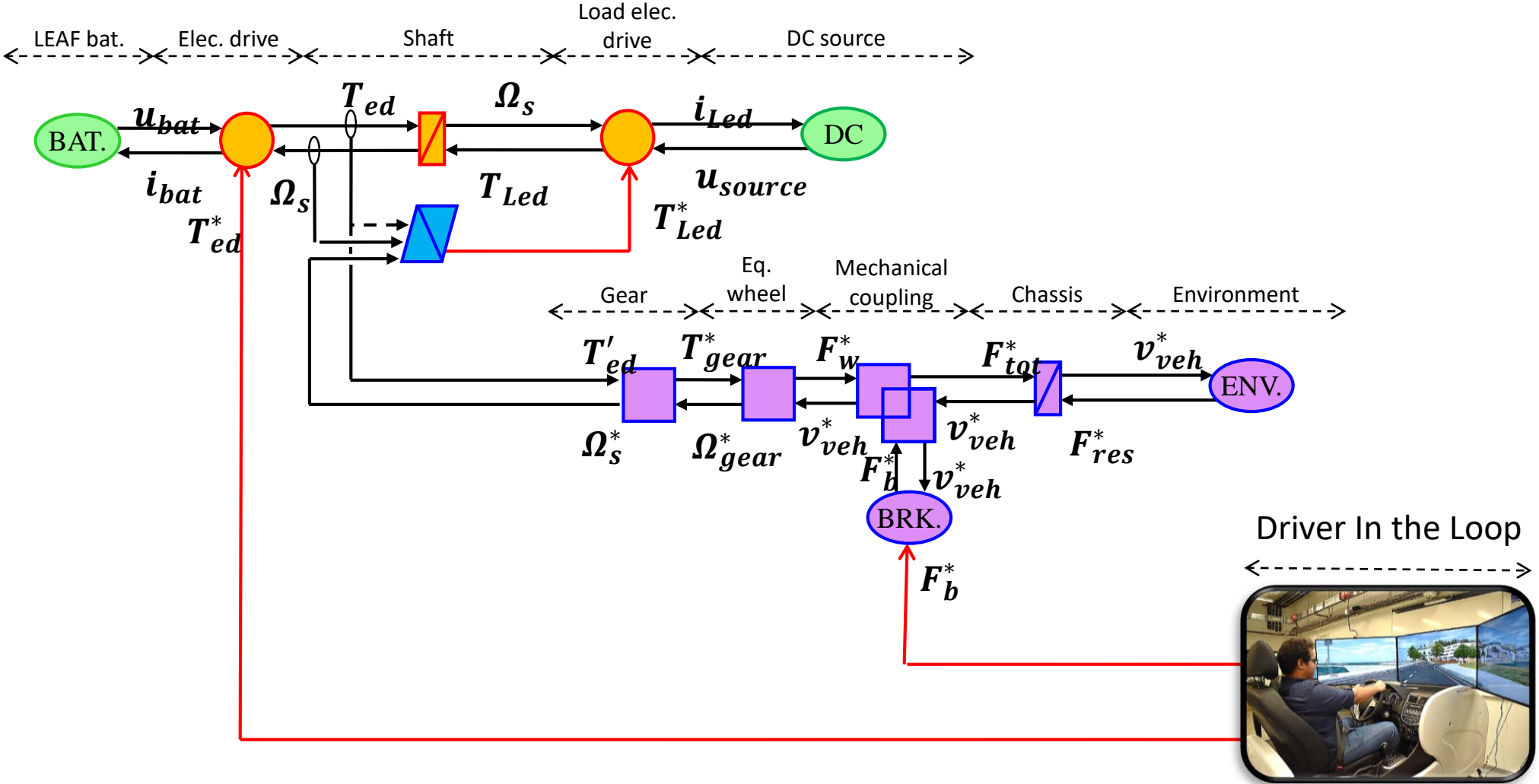

DILAN



<https://cumin.univ-lille.fr/>

Simulation results

Results of the simulation of HIL testing

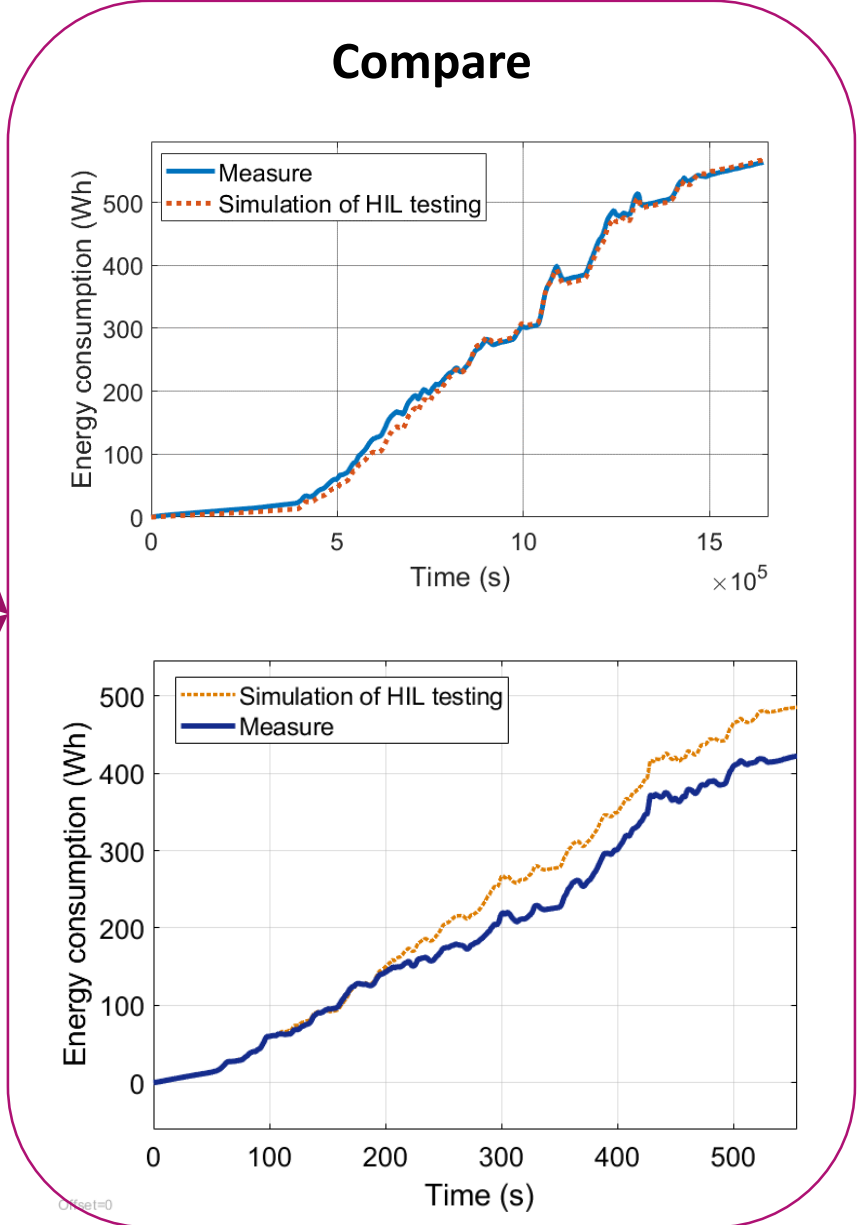
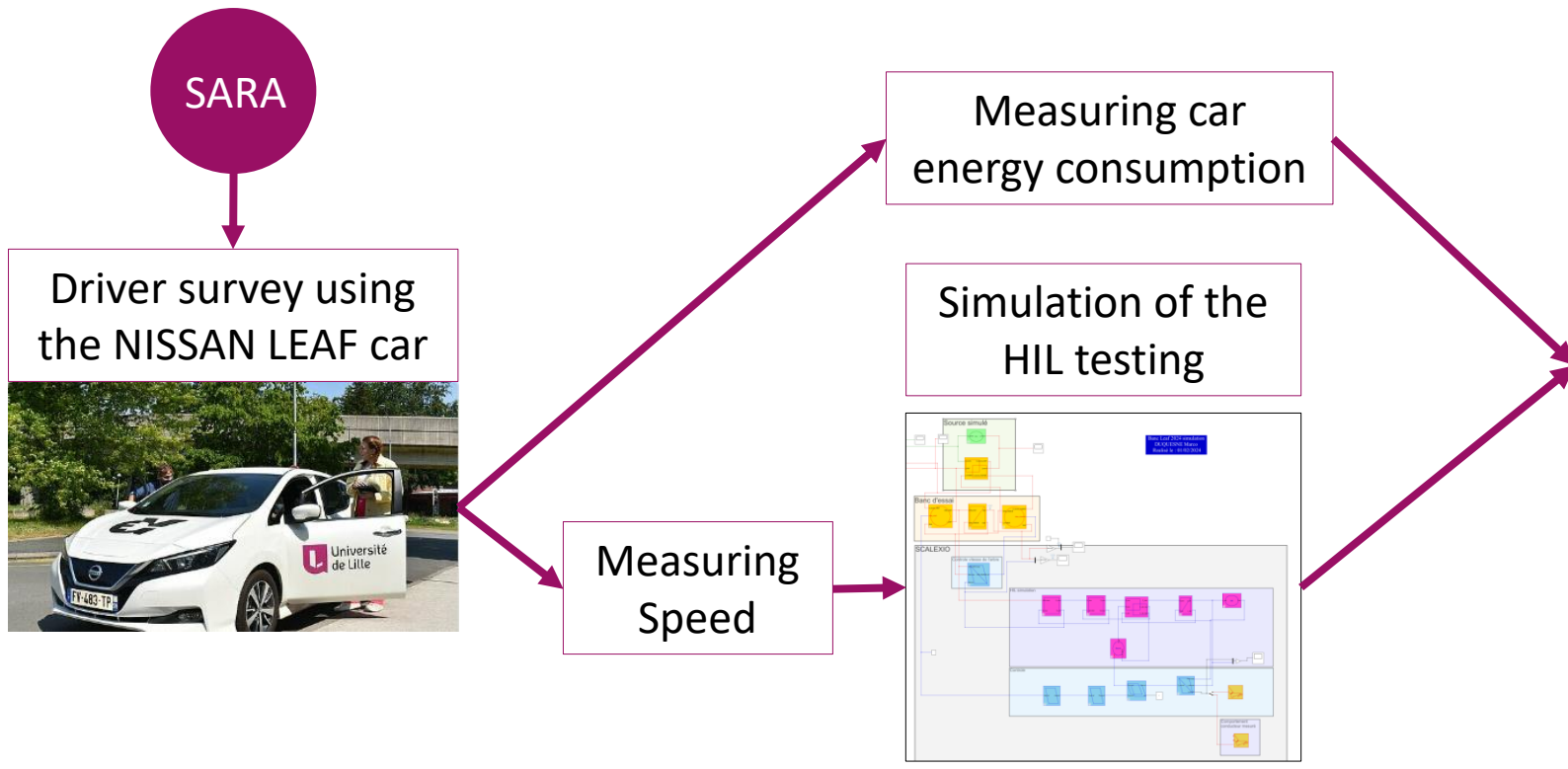



<https://cumin.univ-lille.fr/>

Conclusion



Conclusion

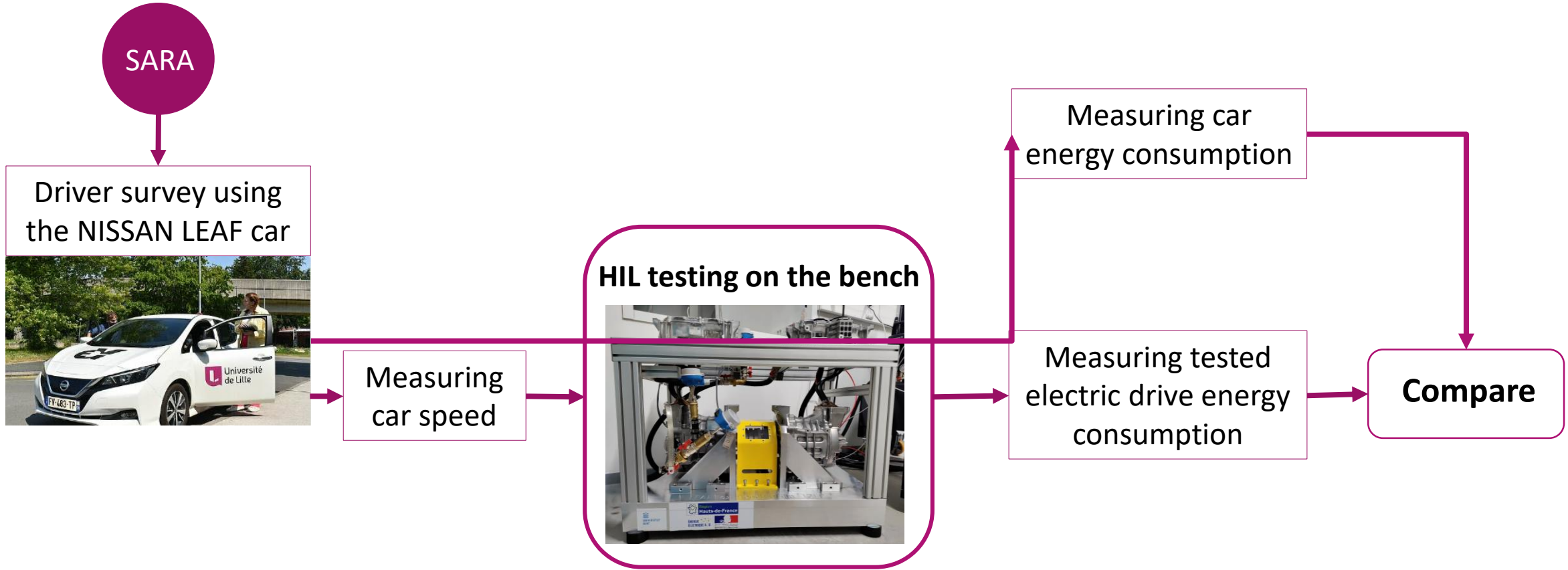



<https://cumin.univ-lille.fr/>

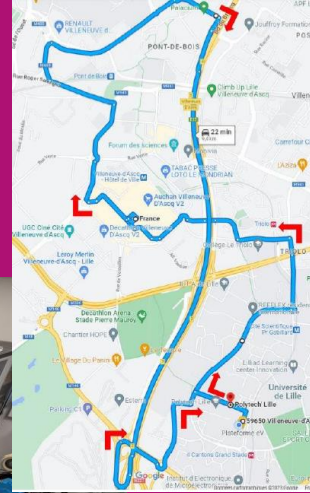
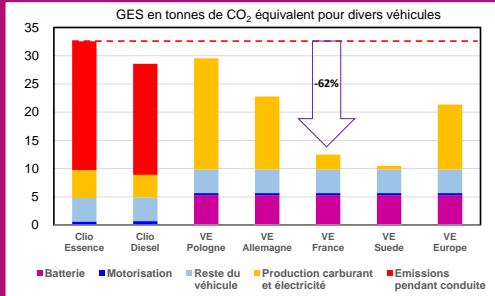

Our university as an exciting living lab towards eco-cities through an innovative transdisciplinary framework !

